

X-Series Signal Analyzer (MXA/EXA) Preselector Tuning for Amplitude Accuracy in Microwave Spectrum Analysis

Application Note 1586

Introduction

While modern spectrum analyzers have been evolving to provide ever-better accuracy at RF frequencies, their accuracy at microwave frequencies has not generally been improving. Indeed the requirements placed on the analyzer user to achieve the best accuracy have become harder to realize with modern signals such as wideband digital modulation. Hardware and algorithms in the X-Series signal analyzers (MXA/EXA) help you maintain the best accuracy without requiring a specific kind of input signal or external test signal.

Microwave spectrum analyzers use preselectors to improve performance by removing unwanted mixer images and responses to local oscillator (LO) harmonics. Unfortunately these preselectors have instabilities and must be retuned frequently, and the preselector tuning previously required a signal of near-CW statistics at the frequency of interest. In the X-Series signal analyzers, noise-source tuning removes this difficult-to-satisfy requirement.



Table of Contents

Introduction.....	1
Low band, high band, and preselection.....	2
Problems with YIG Preselectors	3
Operation of and requirements for preselector centering.....	5
A new centering capability.....	6
Using the X-Series preselector centering capability.....	7
Summary	7



Low band, high band, and preselection

Modern spectrum analyzers operating up to 26.5 GHz have a “low band” and a “high band” signal path, as shown in the simplified block diagram, Figure 1.

The “low band” in the X-Series signal analyzers covers frequencies up to 3.6 GHz. In low band, the signal is upconverted to a high IF (5.1225 GHz), then downconverted to an IF of 322.5 MHz. This double conversion scheme dramatically reduces mixer image responses.

“High band” frequency ranges cannot practically be built with the same block diagram as low band because the first IF amplifier would have to work at a frequency where the amplifier noise and distortion would inevitably be higher than users want. The alternative block diagram is a single conversion to the IF frequency as shown in Figure 1. In this block diagram, image responses in the first mixer are spaced by only twice the IF frequency, or about 600 MHz. Such images are unacceptable in a general purpose spectrum analyzer. Thus the tunable preselector (band-pass filter) is used to filter out the images.

This filter is built using YIG (yttrium-iron-garnet) technology. Spheres of YIG material act to filter the signal with a passband frequency that is controlled by a magnetic field.

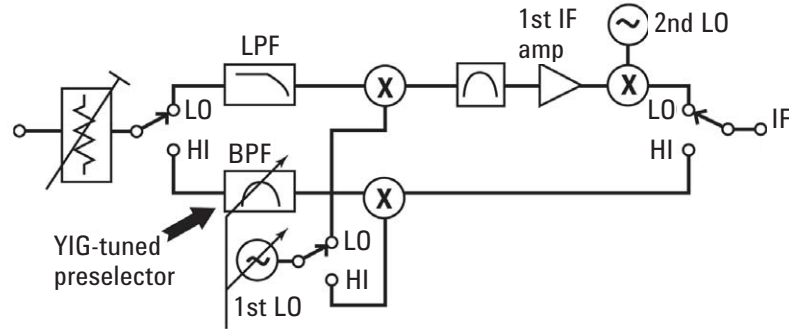

Figure 1: Block diagram of low-band/high-band spectrum analyzer front end

Problems with YIG Preselectors

YIG preselectors usually have a passband width of about 40 to 80 MHz. When used at frequencies up to 26.5 GHz, the required Q s of the resonators are very high. This high Q is accompanied by amplitude and frequency instabilities.

Post-tuning drift is one form of instability. The magnet used to tune the resonant frequency of the YIG spheres heats up or cools down as the selected frequency is changed. The temperature change of the magnet affects the dimensions of the magnet and thus the magnetic field strength, and thus the frequency of the filter tuning.

Mechanical aging of the magnet/sphere structure works in the same way to cause further instabilities.

Also, the relationship between the tuning current and the filter center frequency is not perfectly modeled by any simple algebraic function. Therefore even without tuning instabilities, there are tuning errors. The result is that frequency tuning errors lead to amplitude errors, as demonstrated in Figure 2.

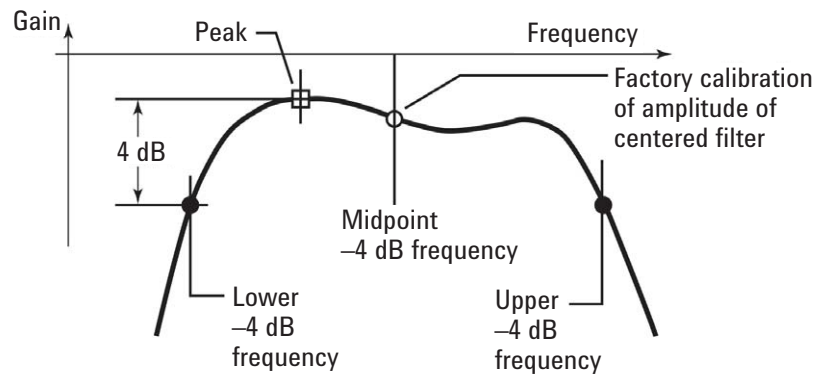

Figure 2A: Typical passband response of a YIG-tuned preselector

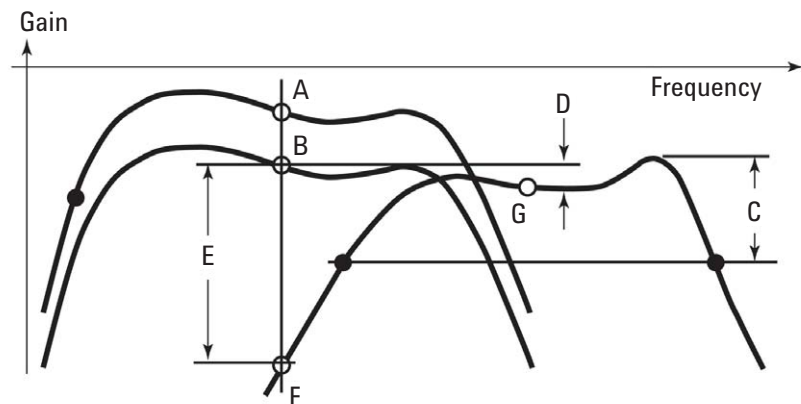

Figure 2B: YIG preselector passband response changes

Problems with YIG Preselectors (continued)

Figure 2A shows a typical YIG filter response. The x-axis is frequency, but because frequency is nearly proportional to tuning current, the x-axis can also be thought of as being tuning current. In this example, small tuning current errors map to amplitude errors proportional to the slope of the passband shape at the operating point. The design operating point is the midpoint between the -4 dB response points, because this design is highly robust regarding tuning errors.

The YIG filter can be adjusted by the user of a modern spectrum analyzer. The user may adjust the operating current directly, or he may execute a “preselector center” operation. A “centering” operation, whether done manually or with the automated preselector center key, acts to optimize the robustness of tuning by centering the preselector passband. The robustness of centering and the convenience of having a centering key make centering preferred over peaking. Factory calibration of amplitude response is performed using centering; therefore, peaking would give poorer amplitude accuracy.

The X-Series signal analyzers make this centering operation (and the amplitude accuracy it offers) more practical and accessible through new hardware and algorithms described in the section “A New Centering Capability” on page 6.

Figure 2B demonstrates how important centering can be. In this figure, point A shows the response used for factory calibration of frequency response. This point is on the response curve of a new analyzer at room temperature. Its horizontal location is at the midpoint between the -4 dB (relative to peak) response frequencies.

Point B is on a congruent curve, displaced vertically to indicate the expected total system response changes when the ambient temperature is changed. The influences of post-tuning drift and aging, in addition to ambient temperature changes, could result in the curve with point F on it. In this case, the amplitude error can be quite large. This error is indicated as length E, which is the difference between the response points B and F.

To improve amplitude accuracy, the analyzer should be recentered. Dimension C shows the location of the -4 dB points relative to the peak of the new tuning curve. Recentering results in response as shown with point G. The new error is now distance D, which is much smaller than the distance E.

Operation of and Requirements for Preselector Centering

The “preselector centering” algorithm measures the filter response in order to optimize the tuning. It assumes a CW-like input signal, and observes the relative response as the tuning current is swept. It searches this relative response curve for the -4 dB points, and centers the tuning between these points.

The input signal is required to have amplitude stability during the duration of the sweeping portion of the centering operation. This stability must be well under a decibel so that amplitude variations are not mistakenly treated as passband shape variations. The signal must have minimal frequency modulations as well, for similar reasons. While modulations that are well under 1 MHz in width are acceptable, wideband digital modulations can cause tuning errors. Finally, the signal must have a good signal-to-noise ratio.

These constraints on the input signal can be a problem in practical measurement applications, leading to measurements with significantly reduced amplitude accuracy. Centering cannot occur when measuring low-level harmonics, for example. Centering cannot be used to measure spot noise density. It can't work with increasingly common digital communications signals such as OFDM, W-CDMA, or TDMA formats. It can't work with most radar signals.

Thus, while spectrum analyzer specifications for amplitude accuracy only apply following a preselector center operation, such operations are often impractical without the additional centering algorithms and hardware built into the X-Series signal analyzers.

A New Centering Capability

If the analyzer had a full-range CW signal generator to use for preselector centering, the user would never need to provide a suitable signal. Unfortunately, such a capability isn't economically feasible; however by employing a broadband noise generator and a new centering algorithm, centering without strict signal requirements can be accomplished economically. The block diagram for this new approach, used in the X-Series signal analyzers, is shown in Figure 3.

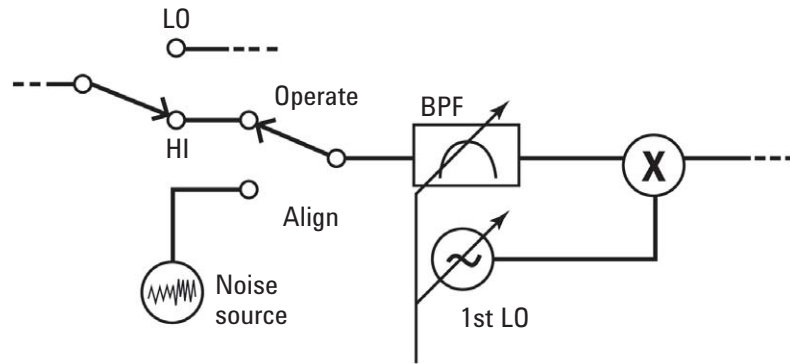

Figure 3: A noise source is added to the block diagram

At first glance, you might think that a noise source wouldn't help tuning. After all, the amount of noise coming out of the filter is nearly independent of the tuning current. But the frequency distribution of that noise does change. The amount of noise that makes it to the IF will vary with the tuning current. See Figure 4.

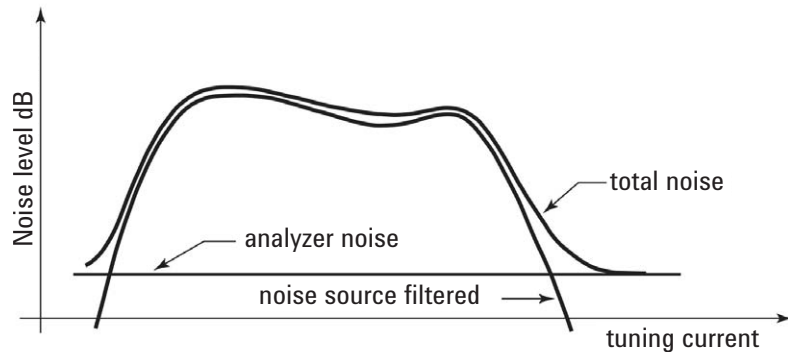

Figure 4: The noise in the IF depends on the analyzer noise floor and the filter tuning

By analyzing the curve of Figure 4, a preselector centering algorithm can center the passband using just the noise source.

Centering can be invoked at every frequency of interest to the user. But the built-in noise source also allows the factory calibration for the overall tuning curve to be implemented in the analyzer and be rerun at will, instead of only on a return to a fully equipped facility. Thus, the effects of aging and (to a much lower level of significance)

ambient temperature changes can be removed by running the "characterize preselector" operation occasionally. With a well-characterized preselector, centering is rarely even needed. Not needing to re-center is even more convenient than a centering operation that doesn't require CW-like signals.

Preselector centering should be manually invoked whenever you want the best (specified) amplitude accuracy for signals in the X-Series' high band, or frequencies above 3.6 GHz.

Traditional centering operations require a signal at the frequency of interest, with a level that is within about 30 dB of the analyzer reference level. The analyzer marker is placed on this signal to identify it and the centering algorithm is invoked by a "Presel Center" softkey on the menu associated with the Amplitude hardkey. An alternative, for non-CW signals, is the "Presel Adjust" operation (and softkey of the same name), where the preselector is manually adjusted without the use of the automatic centering algorithm. This adjustment is normally made by "peaking" the amplitude response and, as described above, is not as robust of a technique for achieving the best amplitude accuracy.

Centering operations are virtually identical for the X-Series signal analyzers, except that no external signals are required, and there is no need for switching input signals or for disconnecting/reconnecting cables to the source being measured. The frequency of interest is typically the analyzer's center frequency, and so it is usually not necessary to activate the marker and move it to the signal of interest. Simply press the Amplitude hardkey followed by the "Presel Center" softkey.

The manual "Presel Adjust" function is also available in the MXA and EXA and operates as it would with other spectrum analyzers, but without the need to supply a signal during adjustment.

Note that the preselector is in the signal path (and adjustments are useful) only if the analyzer is operating at frequencies over approximately 3.6 GHz. The preselector centering and adjustment softkeys are "ghosted" and inactive if the analyzer is measuring lower frequencies

With the addition of a noise source and a new tuning algorithm, the Agilent X-Series signal analyzers can meet their respective microwave amplitude accuracy specifications in the measurement of all signal types, not just high amplitude nearly-CW signals. Furthermore, with the addition of a noise source and new tuning algorithm, these signal analyzers can also meet their microwave amplitude accuracy specifications in the measurement of all signal types, not just high amplitude, nearly-CW signals. For example, in measuring a 40 MHz wide digitally modulated signal at a frequency of 6 GHz, the measurement accuracy without effective preselector centering is not specified and might be worse than -10 dB, while proper centering improves the figure to the warranted ± 1.5 dB.



Agilent Email Updates

www.agilent.com/find/emailupdates
Get the latest information on the products and applications you select.



Agilent Direct

www.agilent.com/find/agilentdirect
Quickly choose and use your test equipment solutions with confidence.



www.agilent.com/find/open
Agilent Open simplifies the process of connecting and programming test systems to help engineers design, validate and manufacture electronic products. Agilent offers open connectivity for a broad range of system-ready instruments, open industry software, PC-standard I/O and global support, which are combined to more easily integrate test system development.

Remove all doubt

Our repair and calibration services will get your equipment back to you, performing like new, when promised. You will get full value out of your Agilent equipment throughout its lifetime. Your equipment will be serviced by Agilent-trained technicians using the latest factory calibration procedures, automated repair diagnostics and genuine parts. You will always have the utmost confidence in your measurements.

Agilent offers a wide range of additional expert test and measurement services for your equipment, including initial start-up assistance, onsite education and training, as well as design, system integration, and project management.

For more information on repair and calibration services, go to:

www.agilent.com/find/removealldoubt

www.agilent.com

For more information on Agilent Technologies' products, applications or services, please contact your local Agilent office. The complete list is available at:

www.agilent.com/find/contactus

Americas

Canada	(877) 894-4414
Latin America	305 269 7500
United States	(800) 829-4444

Asia Pacific

Australia	1 800 629 485
China	800 810 0189
Hong Kong	800 938 693
India	1 800 112 929
Japan	0120 (421) 345
Korea	080 769 0800
Malaysia	1 800 888 848
Singapore	1 800 375 8100
Taiwan	0800 047 866
Thailand	1 800 226 008

Europe & Middle East

Austria	0820 87 44 11
Belgium	32 (0) 2 404 93 40
Denmark	45 70 13 15 15
Finland	358 (0) 10 855 2100
France	0825 010 700*
	*0.125 €/minute
Germany	01805 24 6333**
	**0.14 €/minute
Ireland	1890 924 204
Israel	972-3-9288-504/544
Italy	39 02 92 60 8484
Netherlands	31 (0) 20 547 2111
Spain	34 (91) 631 3300
Sweden	0200-88 22 55
Switzerland	0800 80 53 53
United Kingdom	44 (0) 118 9276201

Other European Countries:

www.agilent.com/find/contactus

Revised: March 27, 2008

Product specifications and descriptions in this document subject to change without notice.

© Agilent Technologies, Inc. 2006, 2008
Printed in USA, May 5, 2008
5989-4946EN



Agilent Technologies